



X-BAND RADAR TRANSMITTER



FEATURES

- 8 - 9 GHz Operating Frequency
- 5 W Saturated Output
- High Gain
- Temperature Compensated (-40°C-+80°C)
- Fast Switching Speed
- Fully Militarized
- Low Spurious Output
- BIT Capability

PERFORMANCE

- Output Power +37 dBm min
- 40 dB Gain min
- 60 ns Rise Time max.
- Pulsed or Average Detector - optional
- -60 dBc Spurious max
- -30 dBc Harmonics max

PACKAGING

- Hermetically Sealed
- SMA Interface
- Low Profile
- Finish: Gray Epoxy Paint
- Size: 4.0" x 2.45" x 0.70"

APPLICATIONS

- Portable Ground
- Surveillance Radar

OUTLINE DIAGRAM

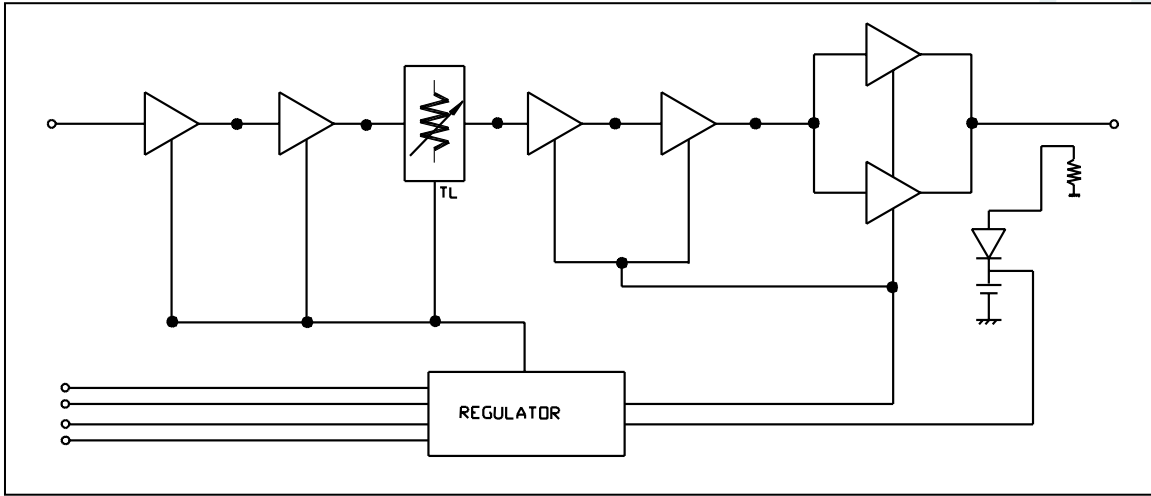

CHARACTERISTICS

PARAMETER	UNITS	MIN.	MAX.	TYPICAL
Frequency	GHz	8.5	9.0	
Output Power (incl. BIT Circuit Losses)	dBm			
P1dB Comp		+36.2		
PSAT		+37.5		
Gain	dB	40		
Gain Flatness	dB	-1	+1	
Gain Stability (-40°C to +70°C)	dB		2	
VSWR				
Input			2:1	
Output (output protected under any VSWR)			3:1	
Noise Figure	dB		10	
Duty Cycle	%		10	
Supply				
DC Input	V	16	32	
External Synch, TTL input (for synchronizing the switching regulation)	kHz			200
DC Switching Control				
TTL Interface	TTL - "1" - Power Off TTL - "0" - Power On			
Switching Time (from 50% TTL to either 10% or 90% RF output)	nS			200
Efficiency Operating	Drain efficiency will be approximately 17%.			
BIT Circuit				
TTL Interface	TTL "0" - P _{out} < 30 dBm TTL "1" - P _{out} > 34 dBm			
Rise Time	nS		60	
Spurious	dBc		-60	
Harmonics	dBc		-30	
Operating Temperature Range	°C	-40	+70	

Specifications are subject to change without notification. Consult Nanowave Technologies, Inc. for specific applications/requirements.